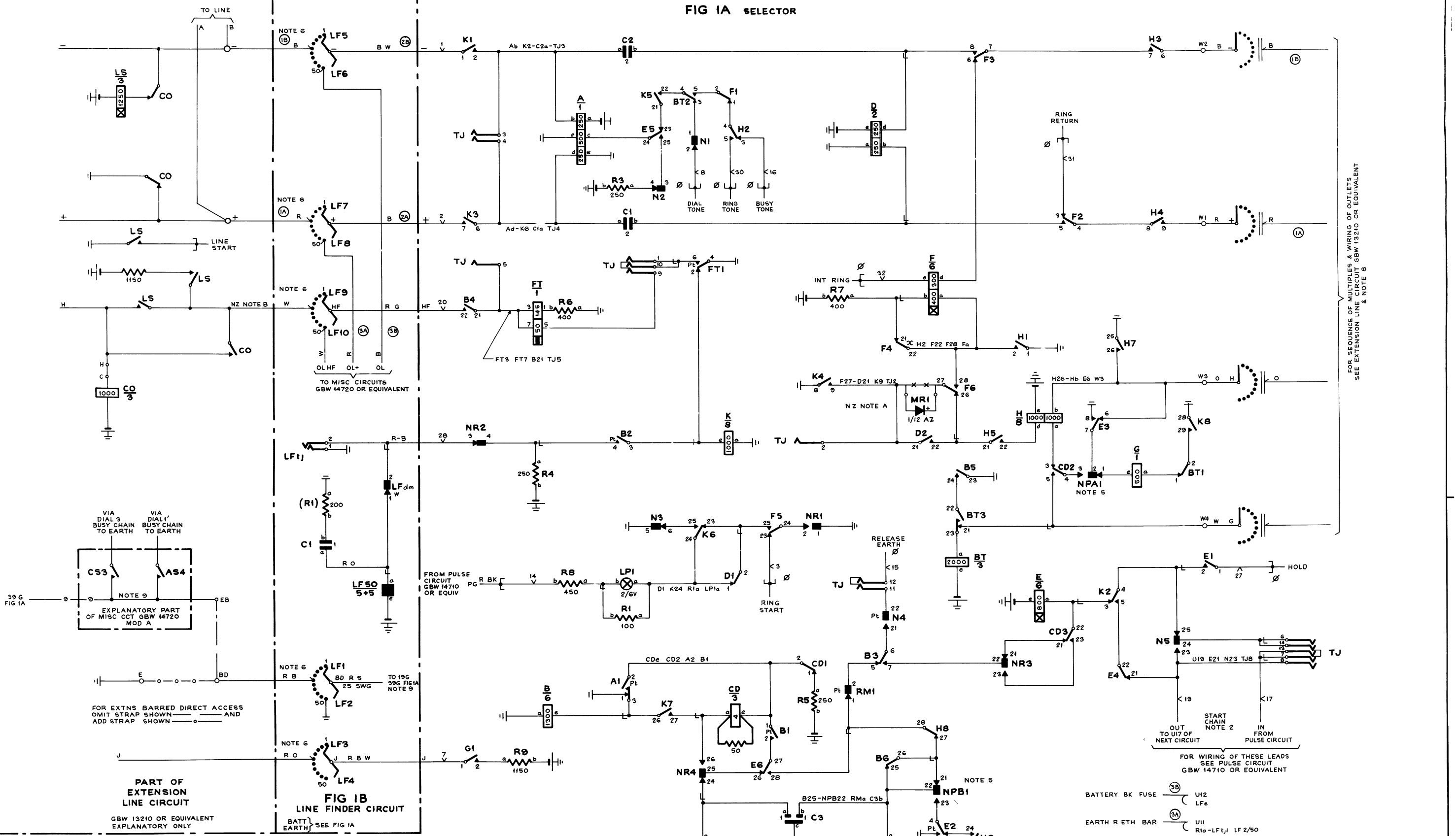
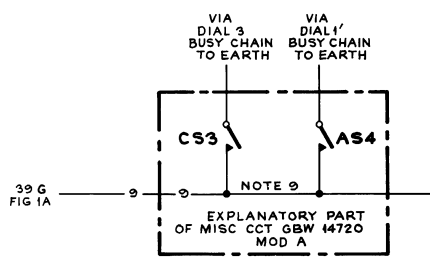

FIG 1A SELECTOR



FOR SEQUENCE OF MULTIPLES & WIRING OF OUTLETS
SEE EXTENSION LINE CIRCUIT GBW 13210 OR EQUIVALENT
& NOTE B



FOR EXTNS BARRED DIRECT ACCESS
OMIT STRAP SHOWN ——— AND
ADD STRAP SHOWN ———

PART OF
EXTENSION
LINE CIRCUIT
GBW 13210 OR EQUIVALENT
EXPLANATORY ONLY

FIG 1B
LINE FINDER CIRCUIT
BATT EARTH SEE FIG 1A

- NOTES**
- 1 FUSING 1.5A PER CIRCUIT
 - 2 JACK POINTS U9 & 11 AND U17 & 19 MAKE CONTACT WHEN RELAY SET IS REMOVED
 - 3 Ø FOR WIRING SEE GBW 13300 OR EQUIVALENT
 - 4 ALL WIRING BEARING A COLOUR CODE TO BE 23 SWG UNLESS OTHERWISE SPECIFIED BANK & SELECTOR WIRING TO BE 25 SWG
 - 5 NPA SPRINGS MAKE ON NZ LEVELS 8 7 6 5 & 0 } 35 LINE
NPB SPRINGS MAKE ON NZ LEVELS 9 4 3 2 1 & 0 }
NPA SPRINGS MAKE ON NZ LEVELS 8 7 6 5 4 & 0 } 49 LINE
NPB SPRINGS MAKE ON NZ LEVELS 9 3 2 1 & 0 }
 - 6 FOR SEQUENCE OF MULTIPLES & WIRING OF OUTLETS
SEE EXTENSION LINE CIRCUIT GBW 13210 OR EQUIVALENT
 - 7 LEVEL & CONTACT NUMBERS SHOWN ARE IN ACCORDANCE
WITH REVERSE NUMBERED NZ DIAL BPO NUMBERING
CORRESPONDING TO NZ NUMBERS 0 1 2 3 4 5 6 7 8 9
1 5 0 9 8 7 6 5 4 3 2 1 RESPECTIVELY

- 8 MISCELLANEOUS CONNECTIONS FROM BANKS**
- | | | | |
|-------------|-----|---------------------------------------------------------------------|------------------------------------------|
| CONTACT 19H | Ø | AS EXCH LINE DIAL '1' START | FROM MISC CCT
GBW 14720 OR EQUIV |
| CONTACT 20H | Ø | BS NIGHT SERVICE START | |
| CONTACT 39H | Ø | CS EXCH LINE DIAL 3 START | FROM MISC CCT
GBW 14720 OR EQUIVALENT |
| CONTACT 19G | R S | FROM LF 1/W FIG 1B NOTE 9 | |
| CONTACT 39G | R B | NIGHT SERV BUSY EARTH | FROM MISC CCT
GBW 14720 OR EQUIVALENT |
| CONTACT 08H | Ø | OL H | |
| CONTACT 08+ | R 2 | OL H } ATTS LINE | FROM MISC CCT
GBW 14720 OR EQUIVALENT |
| CONTACT 08- | B 2 | OL H } ATTS LINE | |
| CONTACT 09H | Ø | OL W FROM ATTS LINE CCTS | FROM MISC CCT
GBW 14720 OR EQUIVALENT |
| CONTACT 09G | Ø | | |
| CONTACT 99G | Ø | | FROM MISC CCT
GBW 14720 OR EQUIVALENT |
| CONTACT 49G | Ø | | |
| CONTACT 39G | R S | 35 LINE PBX ONLY
FROM CS 22 (SPRING SET CS 3)
GBW 14720 MOD A | |
- 9 WHEN ACCESS TO DIAL '3' ROUTE BY BARRED EXTNS IS REQD PROVIDE
CONNS SHOWN ———, OMIT STRAPS 19G-39G, TOGETHER
WITH STRAP BETWEEN SPRINGSETS AS4 & CS3 (GBW 14720 MOD A)**

- NZ NOTES**
- WHEN ACCESS TO VHF SERVICE VIA AN EXTENSION LINE CCT IS REQUIRED MODIFY CONNECTING CCTS FOR CALLING PARTY RELEASE BY REMOVING WIRING SHOWN & INSERTING RECT MRI & WIRING SHOWN
 - ON SOME 35 LINE SYSTEMS THE HF MULT WIRING IS BROWN INSTEAD OF WHITE

- BATTERY BK FUSE (3B) U12 He De R3b R4b R5b Aa Ee-BTe Vme Rme R7b-R9b
EARTH R ETH BAR (3A) U11 R1a-LFtj LF 2/50
EARTH R ETH BAR 1st G BANK OUTLET 09 MULT TO ALL BANKS
1st G BANK OUTLET 49 MULT TO ALL BANKS (35 LINE PABX ONLY)
1st G BANK OUTLET 99 MULT TO ALL BANKS
- BATTERY W U12 He De R3b R4b R5b Aa Ee-BTe Vme Rme R7b-R9b
EARTH R U11 H25 H1-FT4 Da Ae A1 B23 Ba K28 Ka K8 E5 E8
NR1 N5 R6a R2a

SLOW RELEASE		SLOW OPERAT.	
35/49 LINE PABX			
CONNECTING CIRCUIT			
HAVING 'OUT' SERVICE ON TWO ROUTES (DIAL 1 & 3)			
RETRACED FROM ISS. E.O.F. 91-71 NZ NOTE B AND REVISION (8269) A		F 7 11 73 G.F.E.	
AMENDMENT PARTICULARS		ISSUE DATE APD	
DRAWN A.S.L.		CHECKED R.F.H.	
WIRING R.F.H.		CIRCUIT	
GBW 14660 MOD A			

N 5	NR 4	NPA 1	NPB 1	TJ 14	NZ PO	DRAWN A.S.L.	CHECKED R.F.H.	WIRING R.F.H.	CIRCUIT	SIZE A1
-----	------	-------	-------	-------	-------	--------------	----------------	---------------	---------	---------