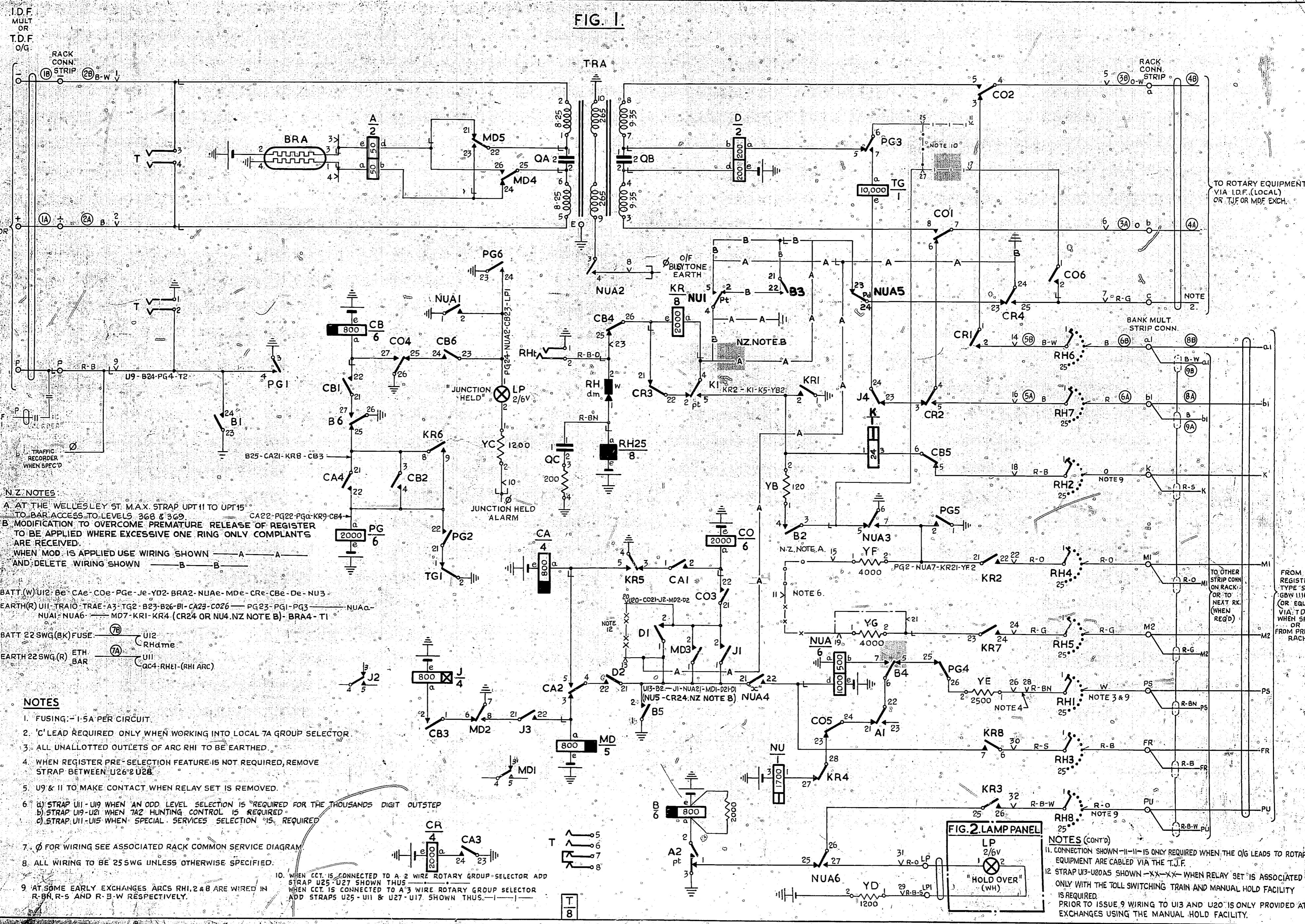

FIG. 1.



NZPO	
DRAWN	
CHECKED	
WIRING	
CIRCUIT	
GBW	1150
INTERWORKING RELAY SET	
(TYPE SR4)	
STEP BY STEP TO ROTARY	
4 SELECTION	
REF. N.Z. P.O. DRG. 18719	SIZE M 150V
ISSUE	DATE
APPRO.	

N.Z. NOTES:

A. AT THE WELLESLEY ST. M.A.X. STRAP UPT 11 TO UPT 15 TO BAR ACCESS TO LEVELS 368 & 369. CA22-PG22-PG4-KR9-CB4

B. MODIFICATION TO OVERCOME PREMATURE RELEASE OF REGISTER TO BE APPLIED WHERE EXCESSIVE ONE RING ONLY COMPLAINTS ARE RECEIVED.

WHEN MOD. IS APPLIED USE WIRING SHOWN A AND DELETE WIRING SHOWN B

BATT (W) U12: Be CAe COe PGe Je YD2 BRA2 NU Ae MDe CR e CBe De NU 3

EARTH (R) U11-TRA10-TRAE-A3-TG2-B23-B26-B1-CA23-CO26 PG23-PG1-PG3 NU Aa

NUA1-NUA6 MD7-KR1-KR4 (CR24 OR NU4.NZ NOTE B)-BRA4-T1

BATT 22 SWG(BK) FUSE U12 Rhdme

EARTH 22 SWG(R) BAR U11 ac4-RHE1-(RHI ARC)

- NOTES**
- FUSING: -1.5A PER CIRCUIT.
 - 'C' LEAD REQUIRED ONLY WHEN WORKING INTO LOCAL 7A GROUP SELECTOR.
 - ALL UNALLOTTED OUTLETS OF ARC RHI TO BE EARTHED.
 - WHEN REGISTER PRE-SELECTION FEATURE IS NOT REQUIRED, REMOVE STRAP BETWEEN U26 & U28.
 - U9 & U11 TO MAKE CONTACT WHEN RELAY SET IS REMOVED.
 - STRAP U11-U19 WHEN AN ODD LEVEL SELECTION IS REQUIRED FOR THE THOUSANDS DIGIT OUTSTEP
 - STRAP U19-U21 WHEN 7A2 HUNTING CONTROL IS REQUIRED
 - STRAP U11-U15 WHEN SPECIAL SERVICES SELECTION IS REQUIRED
 - Ø FOR WIRING SEE ASSOCIATED RACK COMMON SERVICE DIAGRAM.
 - ALL WIRING TO BE 25 SWG UNLESS OTHERWISE SPECIFIED.
 - WHEN C.T. IS CONNECTED TO A 2 WIRE ROTARY GROUP-SELECTOR ADD STRAP U25-U27 SHOWN THUS
 - AT SOME EARLY EXCHANGES ARCS RHI, 2 & 8 ARE WIRED IN R-BN, R-S AND R-B-W RESPECTIVELY.
 - WHEN C.T. IS CONNECTED TO A 3 WIRE ROTARY GROUP SELECTOR ADD STRAPS U25-U11 & U27-U17 SHOWN THUS

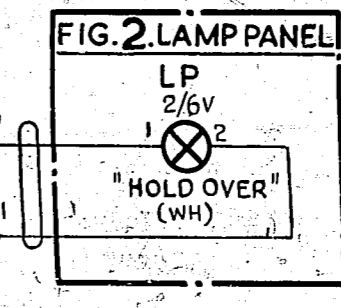

- NOTES (CONT'D)**
- CONNECTION SHOWN -11-11 IS ONLY REQUIRED WHEN THE O/G LEADS TO ROTARY EQUIPMENT ARE CABLED VIA THE T.J.F.
 - STRAP U13-U20A5 SHOWN -XX-XX- WHEN RELAY SET IS ASSOCIATED ONLY WITH THE TOLL SWITCHING TRAIN AND MANUAL HOLD FACILITY IS REQUIRED. PRIOR TO ISSUE 9 WIRING TO U13 AND U20 IS ONLY PROVIDED AT THOSE EXCHANGES USING THE MANUAL HOLD FACILITY.