

AS SEEN FROM REAR

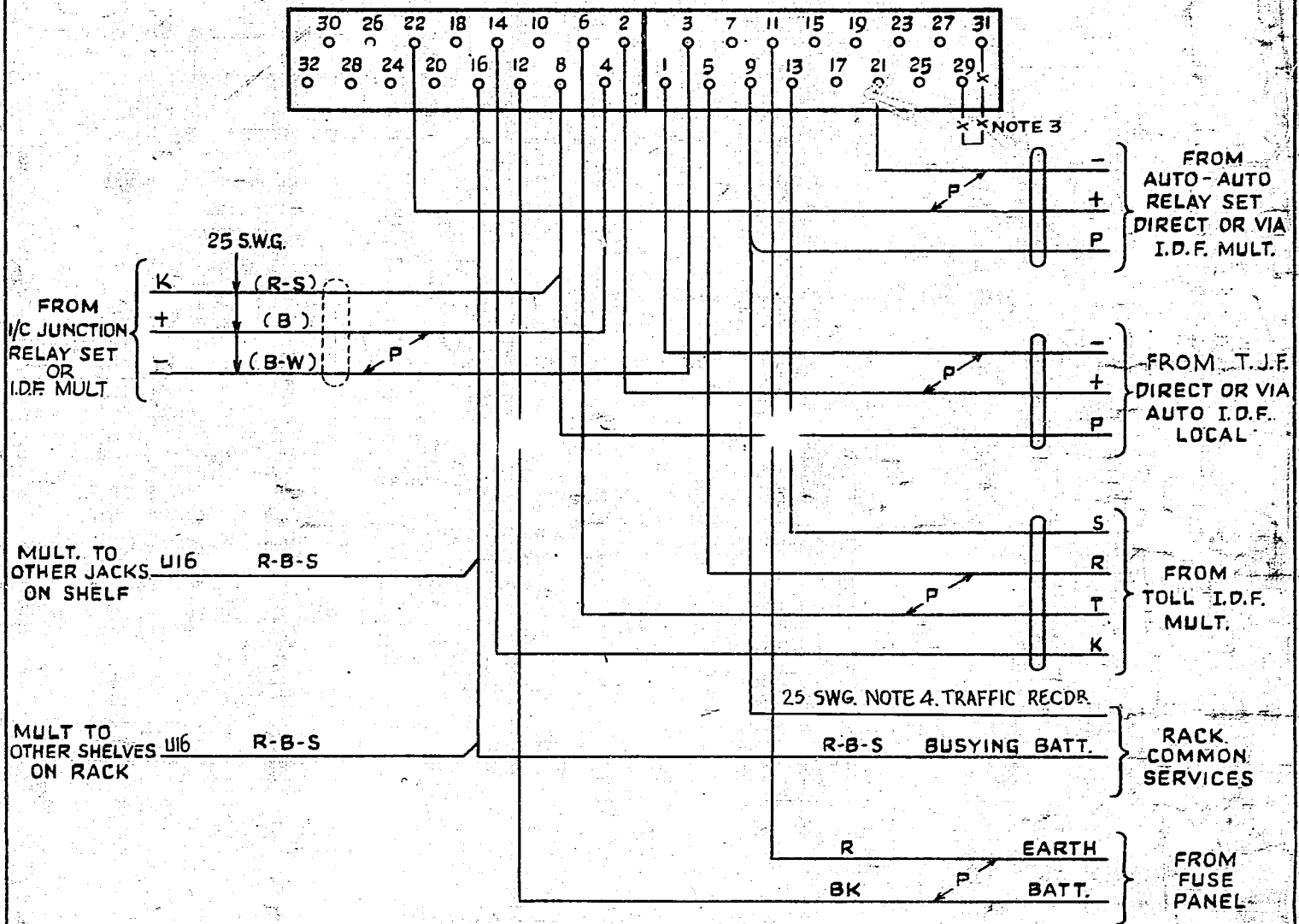

NOTES

1. SHELF JACK POINTS 1 & 3, 2 & 4, 9 & 11 AND 14 & 16 MAKE CONTACT WHEN RELAY SET IS REMOVED.
2. ALL WIRING TO BE 22 SWG. UNLESS OTHERWISE SPECIFIED.
3. CUT STRAP BETWEEN JACK POINTS 29 & 31 WHEN JUNCTION RESISTANCE IS LESS THAN 200 OHMS.
4. COLOURS OF TRAFFIC RECORDER LEADS.
 1ST PAIR OF SHELVES R-O; 2ND PAIR R-G; 3RD PAIR R-BN.
 4TH " " " R-S; 5TH PAIR R-B-W.

			O/G JUNCTION RELAY SET TOLL-AMX	
ALTERNATIVE DESTINATION ADDED TO LEADS FROM U3, 4 & 8 (56574)			4	13.4.62 <i>WLB</i>
REFERENCE TO T.J.F. ADDED. (28412)			3	16.11.59 <i>OK</i>
TRAFFIC RECORDER LEAD & NOTE 4 ADDED (32476)			2	14.7.59 <i>OK</i>
(11089)			1	12.12.57 <i>WLB</i>
AMENDMENT PARTICULARS			ISSUE	DATE. APPD
			50V / E	
			GBU 15270	
DRAWN			CHECKED WIRING CIRCUIT	
N.Z.P.O	5	Centimetres	10	15
			20	