

AS SEEN FROM REAR

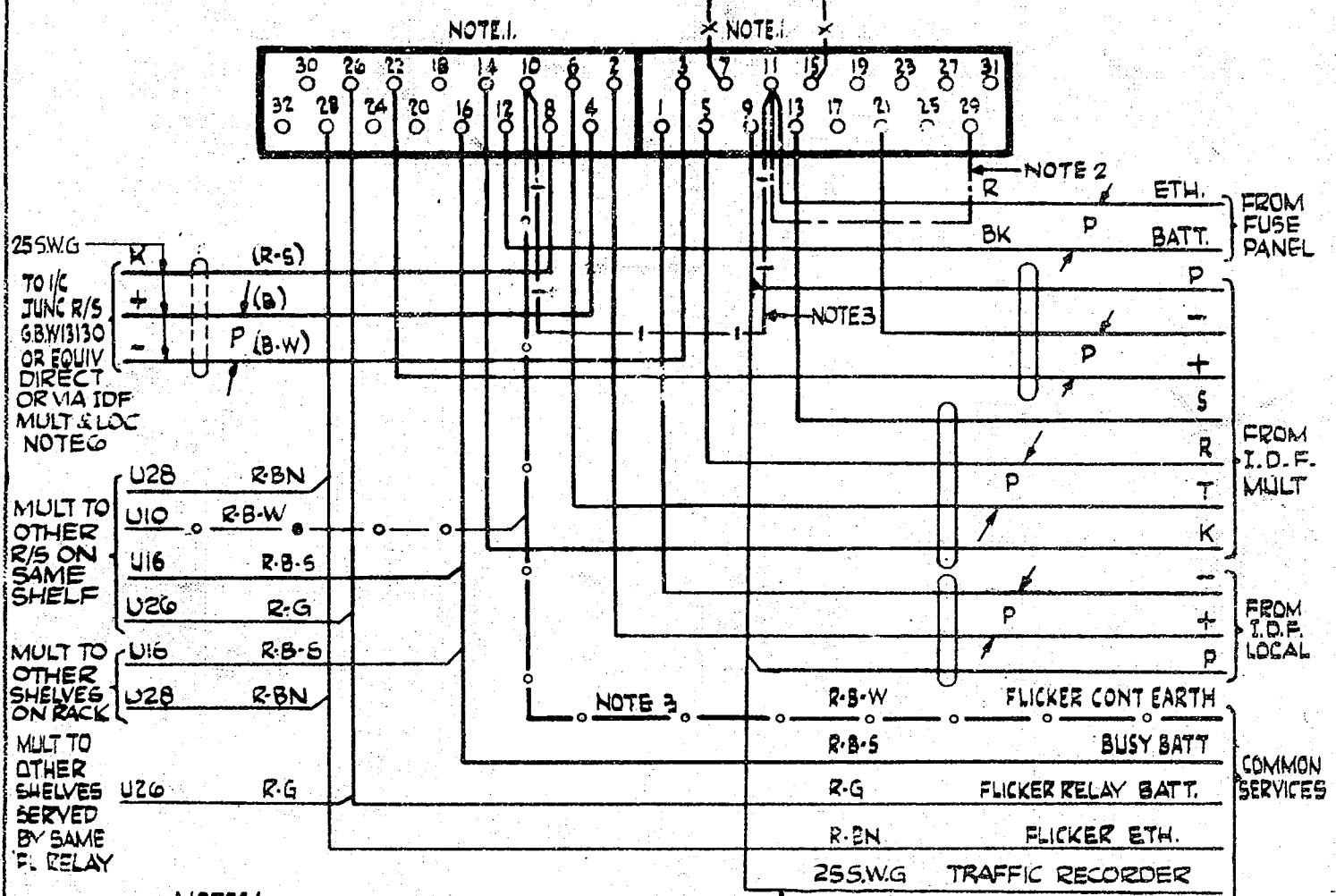

NOTES:-

1. SHELF JACK POINTS U1&U3, U2&U4, U9&U11, U14&U16 TO MAKE CONTACT WHEN RELAY SET IS REMOVED.
2. WHEN CIRCUIT IS ASSOC'D WITH AN UNREPEATERED LINE UNDER 3db, CONNECT WIRING SHOWN THUS
3. WHEN FLICKER EARTH IS NOT REQ'D DISCONNECT WIRING SHOWN THUS & CONNECT WIRING SHOWN THUS
4. ALL WIRING UNLESS OTHERWISE SPEC'D TO BE 255.W.G.
5. WHEN JUNCTIC. EXCEEDS 500Ω CONNECT WIRING SHOWN THUS
6. FOR B/W WORKING CONNECT +, - & K TO 1/C RELAY SET GBW13130

1<sup>ST</sup> PAIR OF SHELVES R-O  
 2<sup>ND</sup> PAIR OF SHELVES R-G  
 3<sup>RD</sup> PAIR OF SHELVES R-BN  
 4<sup>TH</sup> PAIR OF SHELVES R-S  
 5<sup>TH</sup> PAIR OF SHELVES R-B-W.

TRAFFIC RECORDER & NOTE 6 WAS NOT SHOWN	7.	25359	OK	(26350)
ALTYE WIRING FROM U3, U4 & U8 TO I.D.F. WAS NOT SHOWN	6.			
U9 & U29 WIRING MOD. WIRING TO GBW13130 WAS 205.W.G.	5.			
WIRING FROM U1, 2 & 8 REVISED	4.			
LEADS U21, 22 & 29 WERE NOT SHN. NOTE 1 MOD.	3.			
COMMON SERVICE LEADS U26 & U28 WERE NOT SHN.	2.			
	1.			
AMENDMENT PARTICULARS	ISSUE	DATE	APPD	REF — 653-21-16 TR1039-17-18 502 H
N.Z.P.O.	DRAWN	CHECKED	WIRING	CIRCUIT
	B	R.L. 5/1	R.L.	

SLEEVE CONTROL SYSTEM  
 O/G JUNCTION RELAY SET  
 TOLL-AM.X. WITH TRK OFFER  
 AND SELECTOR ACCESS TO A.M.X.  
 2000TYPE

GBU 13140